

HEMA GR105DB Rotator

GR models from Baltrotor.

The GR models are available in several different variations with different SWL loads, ranging from 1-45 ton – and all rotate continuously.

The rotators can be mounted on virtually all auto cranes and machines with custom suspension.

The GR rotator range is versatile, as its mounting dimensions fit a large part of the existing equipment within the transport industry.

The GR rotators are also distinguished by their relative low weight and physical size, while at the same time, having a high torque.

As the rotators are flexible, they can easily be changed with another model depending on the shaft and bolt dimensions, as well as flange mounting for some models.



Product nr. 3095 9355

**GR105 DB 10,0 Tons
Standard flange 6xØ17
BCD Ø173**



HEMA
K.S.M. Kragelund ApS.
Bøgballevej 19, Kragelund, DK-8723 Løsning
Tlf. + 45 75893711 - Fax. + 45 75893709
Mail: hema@ksm-hema.dk / www.hema.world

Manufacturing and sales of
HEMA Crane Equipment,
and mudguards



ROTATOR GR 105 DB

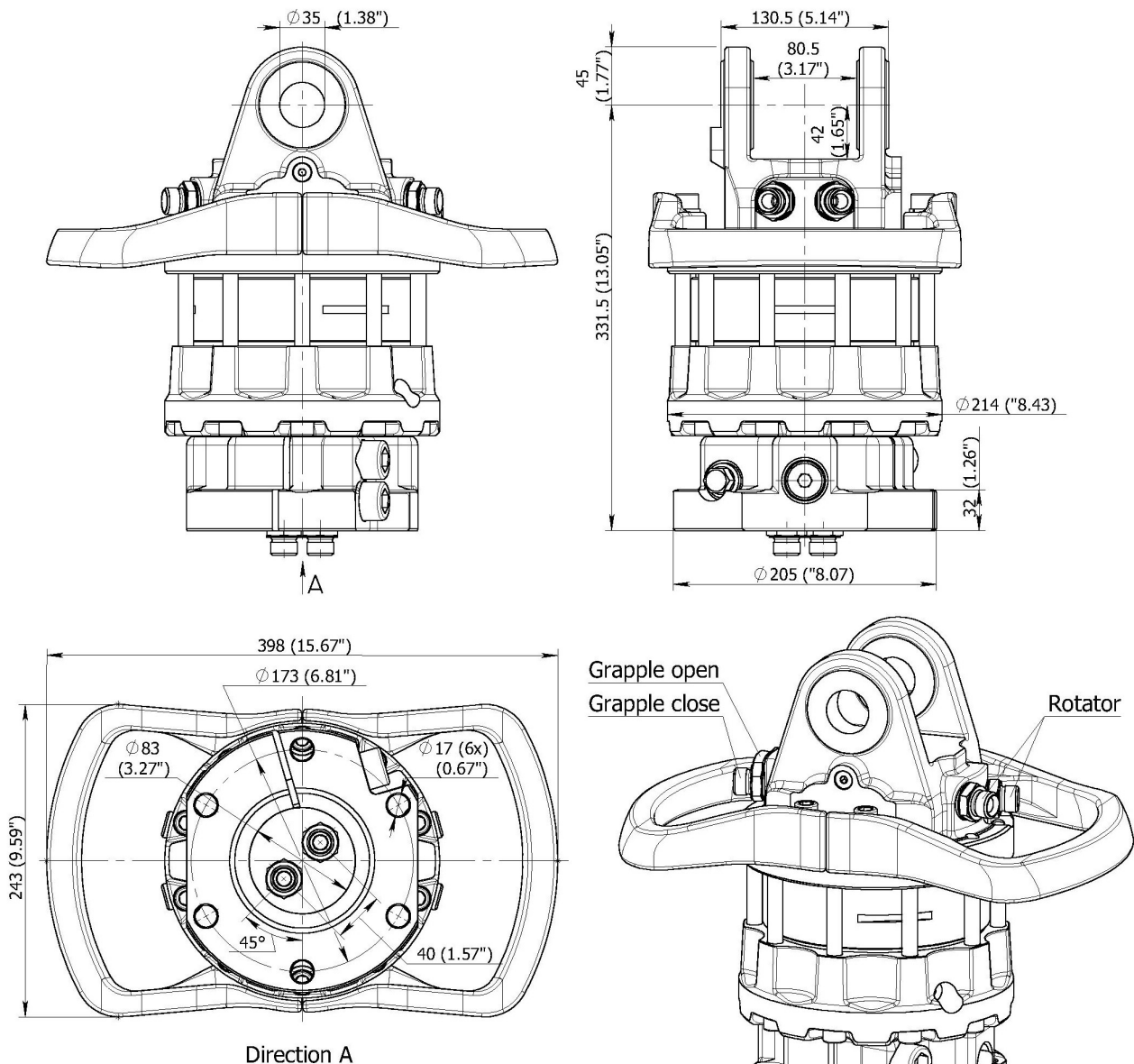

Technical data

Rotation	Unlimited
Max axial load static, KN (lbf)	+100 (22485) - 80 (17985)
Max axial load dynamic, KN (lbf)	+50 (11242) - 40 (8992)
Torque at 25Mpa (3625psi), Nm (lb ft)	2700 (1991)
Rec oilflow, l/min (US gallon)	30 (7.9)
Weight, kg (lb)	62 (137)

Max working pressure:

Rotator	←R→	Max 25 MPa (3625 psi)	G 1/2"
Grapple / Tool open	←G→	Max 30 MPa (4350 psi)	G 1/2"
Grapple / Tool close	→G←	Max 30 MPa (4350 psi)	G 1/2"

Connection:

Grapple close Grapple open