

HEMA GR10-2 Rotator

GR models from Baltrotor

The GR models are available in several different variations with different SWL loads, ranging from 1-45 ton – and all rotate continuously.

The rotators can be mounted on virtually all auto cranes and machines with custom suspension.

The GR rotator range is versatile, as its mounting dimensions fit a large part of the existing equipment within the transport industry.

The GR rotators are also distinguished by their relative low weight and physical size, while at the same time, having a high torque.

As the rotators are flexible, they can easily be changed with another model depending on the shaft and bolt dimensions, as well as flange mounting for some models.

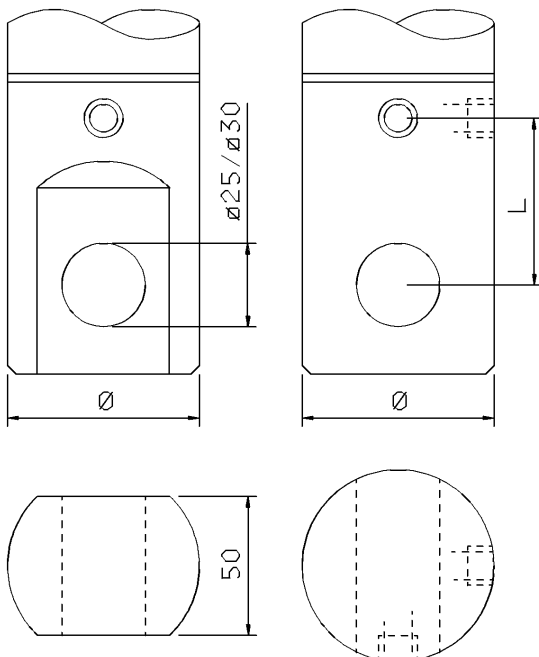

Product nr. 3095 9001

GR10-2 1,0 Tons

Standard axel

Round Ø39,5xØ20 Hole

Double oil feed to tool

Adjustment of link between rotator and tool, see shaft sketch and back of this brochure for dimensions on shafts..

ROTATOR GR10-02

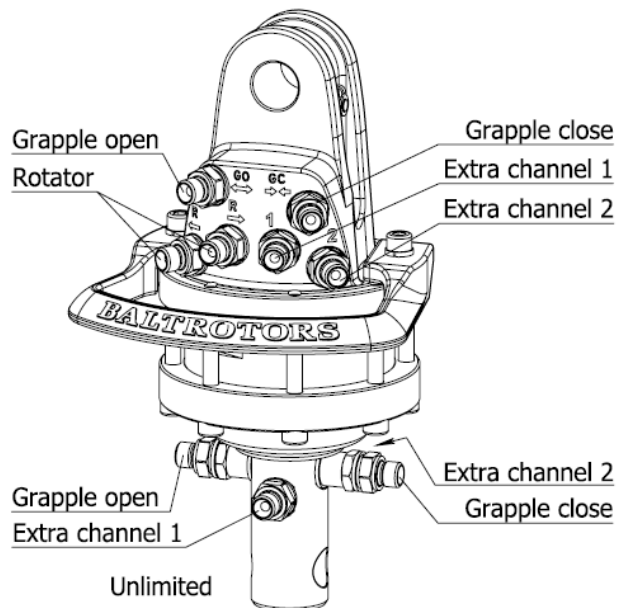
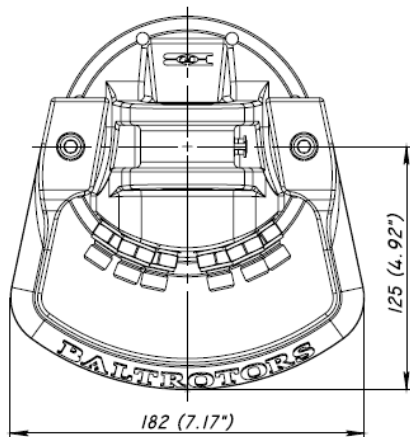
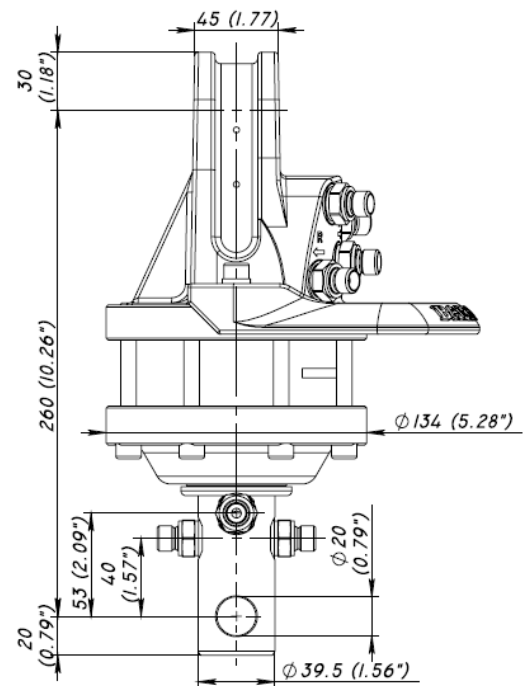
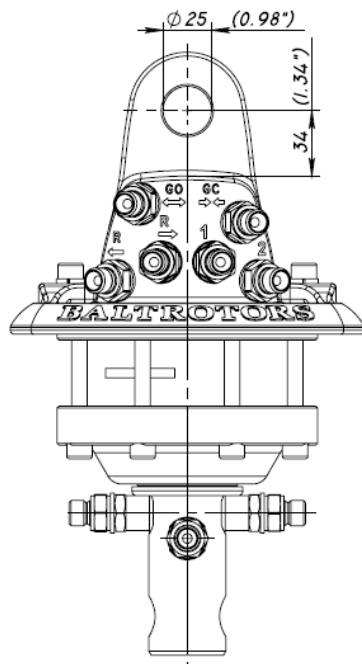

Technical data

Rotation	Unlimited
Max axial load static, KN (lbf)	10 (2250)
Max axial load dynamic, KN (lbf)	5 (1125)
Torque at 25Mpa (3625psi), Nm (lb ft)	450 (330)
Rec oilflow, l/min (US gallon)	10 (2.6)
Weight, kg (lb)	12 (26)

Max working pressure:

Rotator	←R→	Max 25 MPa (3625 psi)	G 1/4"
Grapple / Tool open	←G→	Max 20 MPa (2900 psi)	G 1/4"
Grapple / Tool close	→G←	Max 30 MPa (4350 psi)	G 1/4"
Extra oil function	1 2	Max 30 MPa (4350 psi)	G 1/4"

Connection: